

DESIGN

CLASSIC

2024

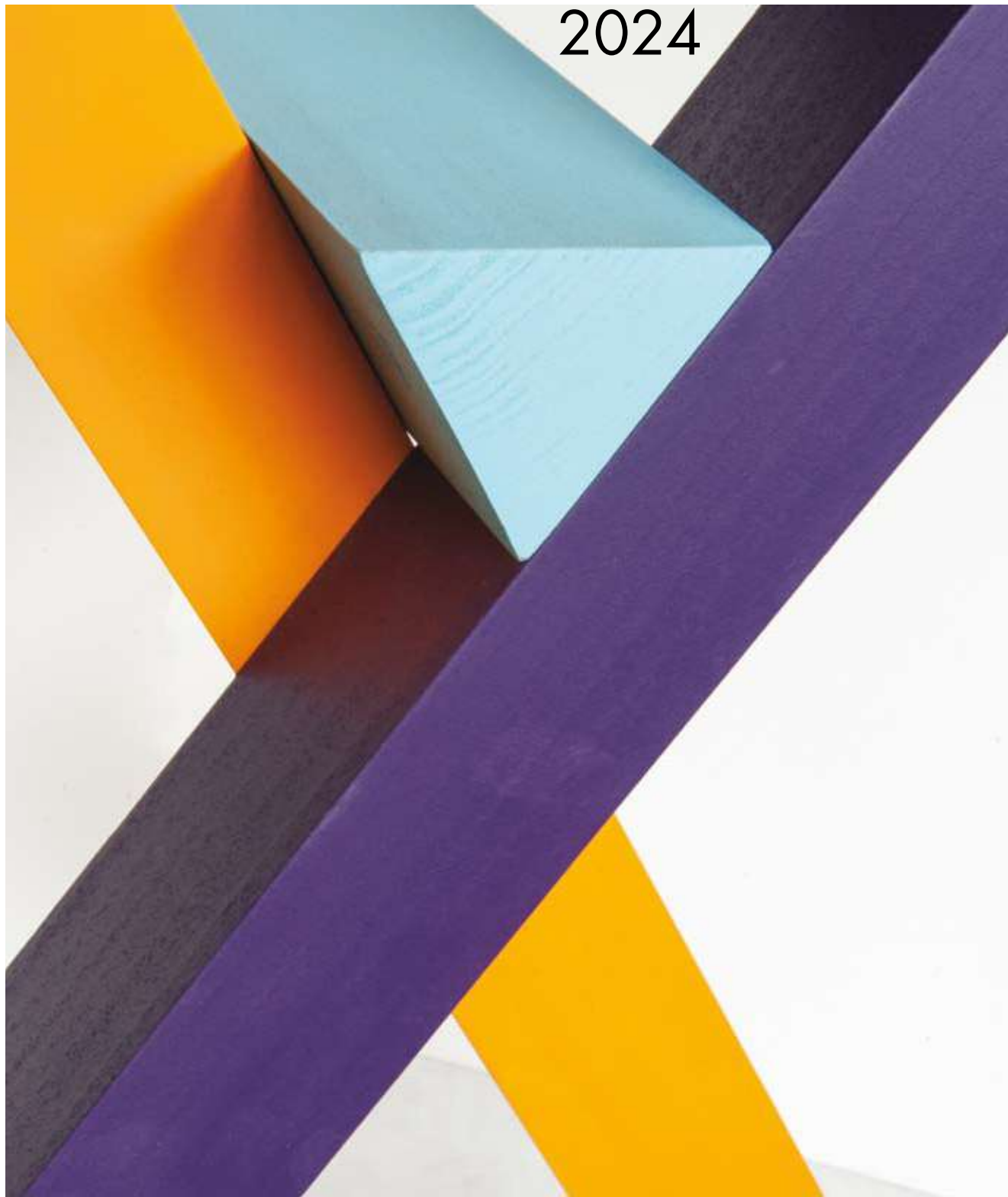

TUTTI I TAVOLI

Nel 2015 abbiamo proposto questa collezione dei nostri progetti intramontabili, che ora completiamo. Perché ci sono forme che rimangono nella memoria. Disegnate, inventate, progettate tempo fa, mantengono però intatta la loro attrattiva: il design diventa classico. Questa collezione è stata formulata con questo pensiero. E diventa la divisione complementi.

*Some shapes remain forever in our memory.
Created, designed years ago, they continue to be attractive
as they were in the beginning.
That's the way a piece of design becomes a classic.
This collection has been selected according with this thought.*



TABLAS

Titti Fabiani design



Ora anche in bianco e nero.
Now in black and white.



Tablas, un fratino di oggi:
proporzioni perfette, legno e cristallo,
tante misure comode,
e la libertà di colori imprevedibili.

*Tablas, a convent table for today:
perfect proportions, crystal and wood,
a number of comfortable sizes,
and the freedom given by unexpected colours.*

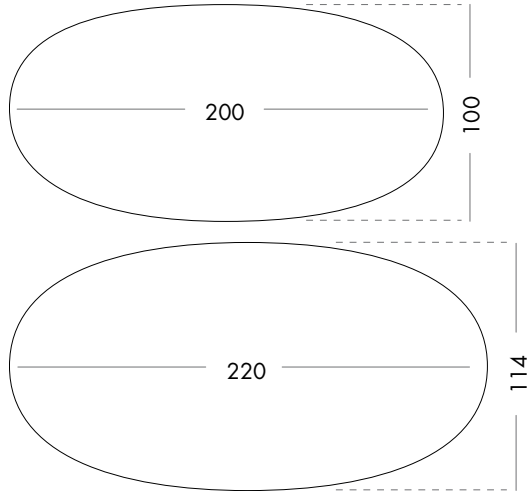

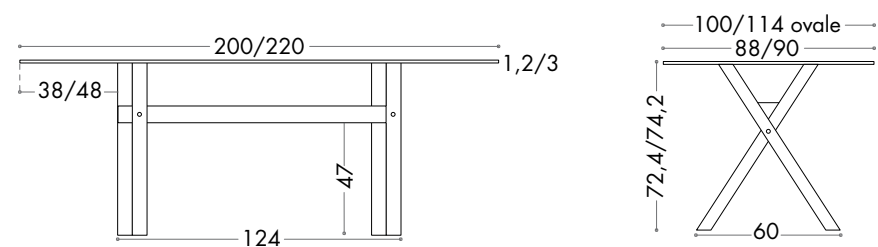

Per un loft a New York,
 Tablas rettangolare,
 in frassino o cristallo.

*Perfect for a Manhattan loft,
 Rectangular Tablas,
 whitened ash or crystal.*

BASIC

Titti Fabiani design

Solidamente hi-tech il Basic oggi si presenta con un piano in frassino e misure perfette per le case di oggi.

Hi-tech, Basic table has now a ash top and perfect dimensions for today homes.

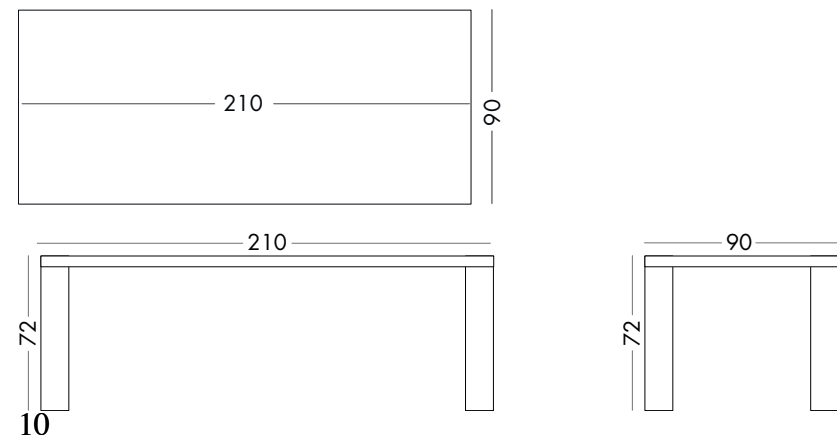





NANO BOOK

Titti Fabiani design

Tavolo in frassino e piano in cristallo.
Piedi in legno o alluminio (nano basic).

Ash structure and glass top.

Feet in wood or aluminium (nano basic).

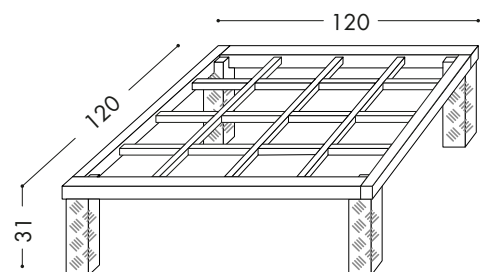

NANO BASIC



BITAVOLO

Titti Fabiani design

Quarant'anni di successi per questo tavolo a parete che si apre, si raddoppia e diventa pranzo.

Forty years of success for this wall table which can be opened, doubled and become a dinner table.

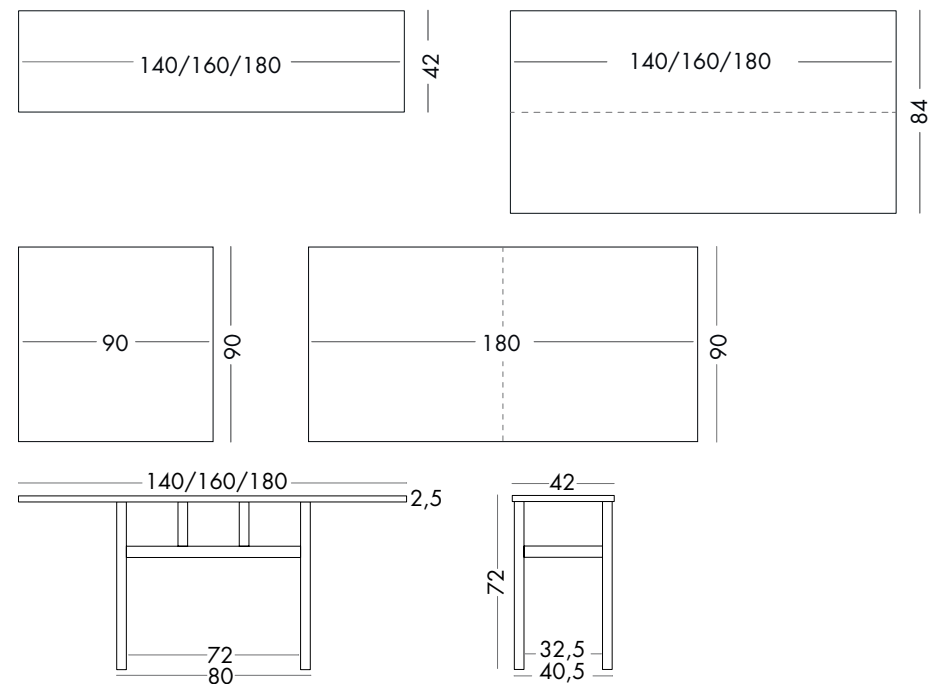

OSPITE

Helix studio design



Ospite rettangolare è un tavolo console.
Quando è chiuso si accosta a muro.
Aperto si raddoppia in larghezza e diventa un tavolo da pranzo.

*Rectangular Ospite is a console table.
When it is closed it moves close to the wall.
When opened it doubles in width and becomes a dining table.*

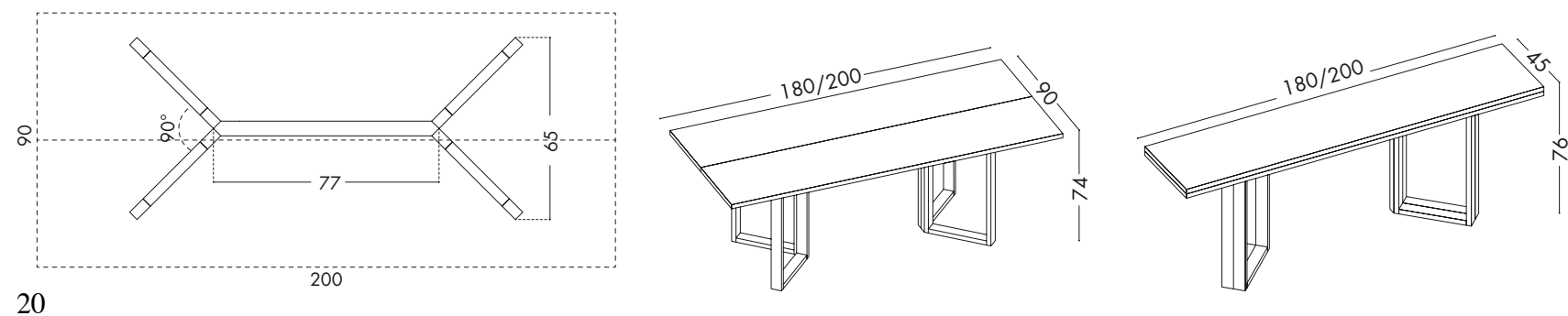

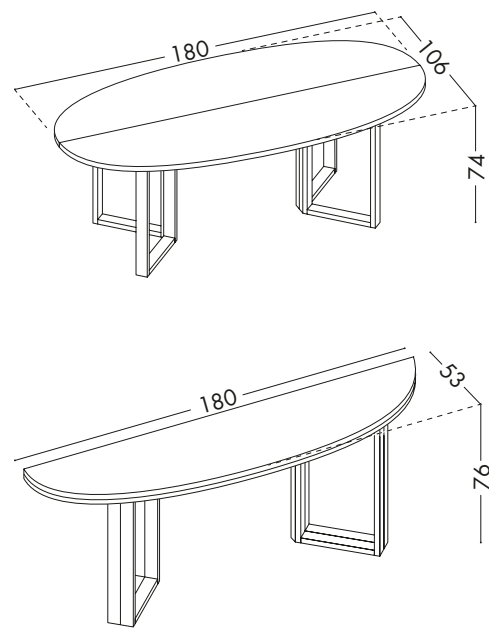

Ospite ovale.

Struttura in massello di Frassino e il piano in Frassino nei colori: naturale sbiancato, naturale “forever”, bianco lipari, nero Stromboli, mogano, noce, noce moka, noce biondo, smoky, antracite.

Oval Ospite.

Structure in solid ash and top in ash in the colours: natural bleached, natural “forever”, lipari white, Stromboli black, mahogany, walnut, mocha walnut, blond walnut, smoky, anthracite.

SCRIBA

Helix studio design

Uno scrittoio piccolo, comodo, lineare.

Piano 130x70 in cristallo, legno, cuoio nero, laminato, e cassetti.

A little, comfortable, elegant writing desk.

Top 130x70, Crystal, Wood, Black Leather, Laminated, and drawers.

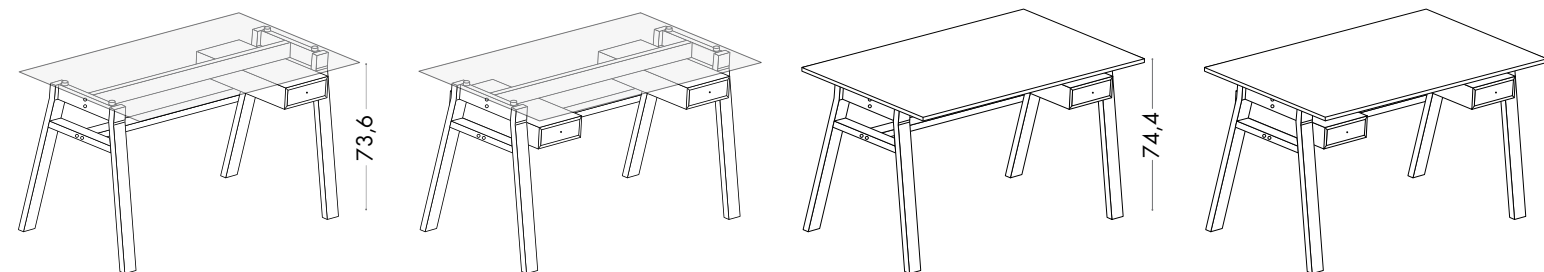



Scriba Cuoio.
Molto, molto tradizionale.

Scriba Leather.
Extremely traditional.



Scriba Legno.

Piano e struttura in frassino a cera.

Due cassetti o uno solo.

Scriba Ash.

Top and structure in waxed ash.

Two drawers – or one only.



Scriba Laminato

Un piano bianco dal bordo in legno,
per la massima luminosità.

Scriba Laminated Plastic.

*A white laminated surface, a waxed wood edge,
extremely bright.*



Scriba tavolo.

Struttura in frassino e piano in cristallo.

200x88 – 220x90

Scriba table.

Ash structure and crystal top.

200x88 – 220x90

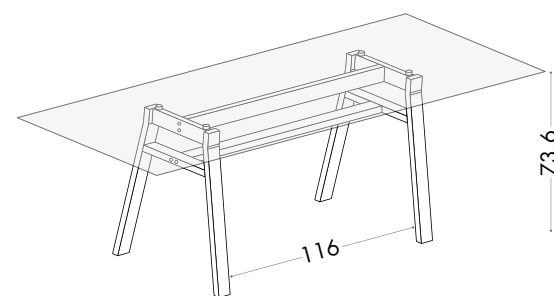

MINISCRIBA

Helix studio design

Struttura e piano in frassino,
disponibile nei colori: Noce, Nero Stromboli,
Naturale Forever o, a richiesta, negli altri colori Book



34

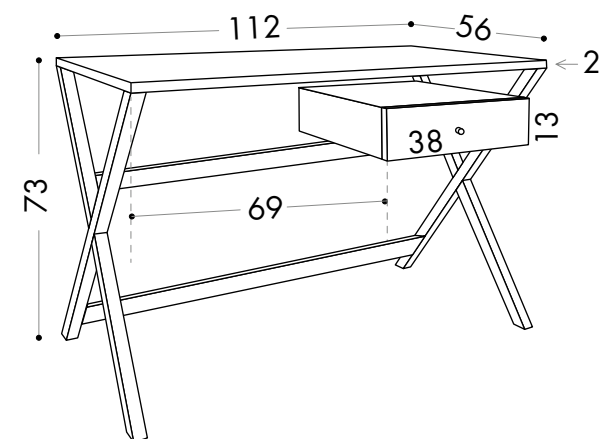

35

TWINS

Helix studio design

Sovrapponibili, piccoli,
colorati, necessari
vicino ai divani...

*Superimposable, little,
coloured, indispensable
near all sofas...*

Nero Stromboli
Bianco Lipari
Noce
Rovere
Sunny
Sunset
Ithaky
Baby

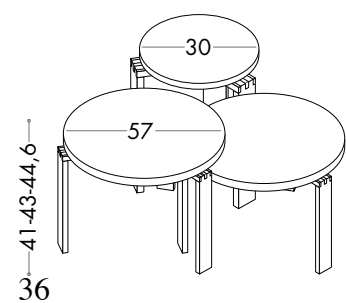

DIVANO PACK

Titti Fabiani design

Struttura in alluminio
o frassino nei colori
del Book.

Cuscini sfoderabili
in cotone Bianco.

*Aluminum or ash
structure – same colours
as Book.*

*Cushions with White
cotton removable covers.*

Pack Divano 210x90 cm - h 70 cm
38



MINICOMODITÀ

Piccole geniali creazioni
per semplificare la vita.

*Brilliant creations
to make life easier.*



HELP

Titti Fabiani design

Uno scaffale snello,
storto e colorato,
e ogni cosa è a posto.

*A slender
and coloured shelf,
to help settling
everything.*





Mare, Bianco Lipari, Navy
Sunset, Mare, Sunny

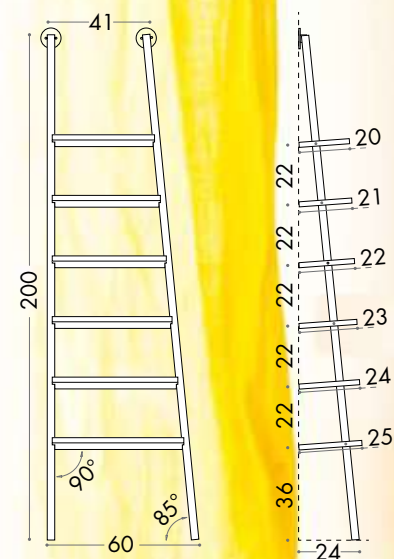

VALLETTO

Helix studio design

Comodo per guardarsi, bello per un po' d'ordine.
Per la camera, il closet o un disimpegno.
È su ruote, basta un dito per spostarlo.

*Look at yourself in this mirror, or just organize.
In your bedroom, a closet or hallway.
Just one finger to move it on its wheels.*

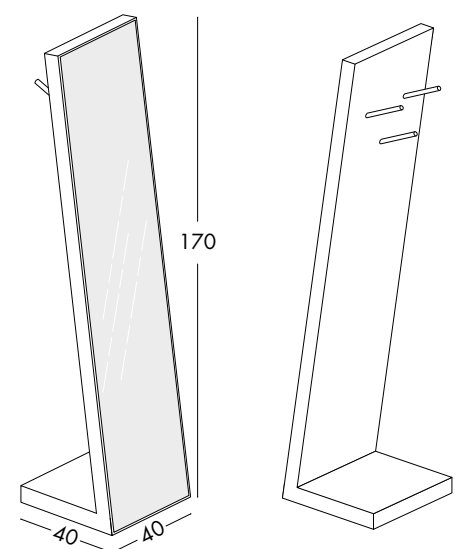

Bianco ottico a poro chiuso
o nel colore che si preferisce
della gamma RAL.

*Optical white closed pore
or in the color you prefer
of the RAL range.*





BEDDO

Helix studio design

Comodo a letto, comodo vicino al letto,
con un cassetto, infilato sotto il letto, su ruote.

*Comfortable, with its drawer and on wheels,
close to, or slipped under your bed,*

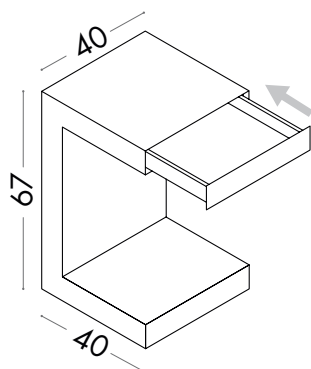

Bianco ottico a poro chiuso
o nel colore che si preferisce
della gamma RAL.

*Optical white closed pore
or in the color you prefer
of the RAL range.*

SPILLO

Helix studio design

Giusto per appendere la giacca,
il mantello degli ospiti,
lo zainetto o la pashmina...
nell'ingresso o in camera,
senza rubare spazio,
ma con una pennellata di colore...

*The right solution to hang a jacket,
the guests' coats, a bag
or your Pashmina... in the entrance
or in the bedroom,
without stealing space,
with a brush-stroke of colour...*

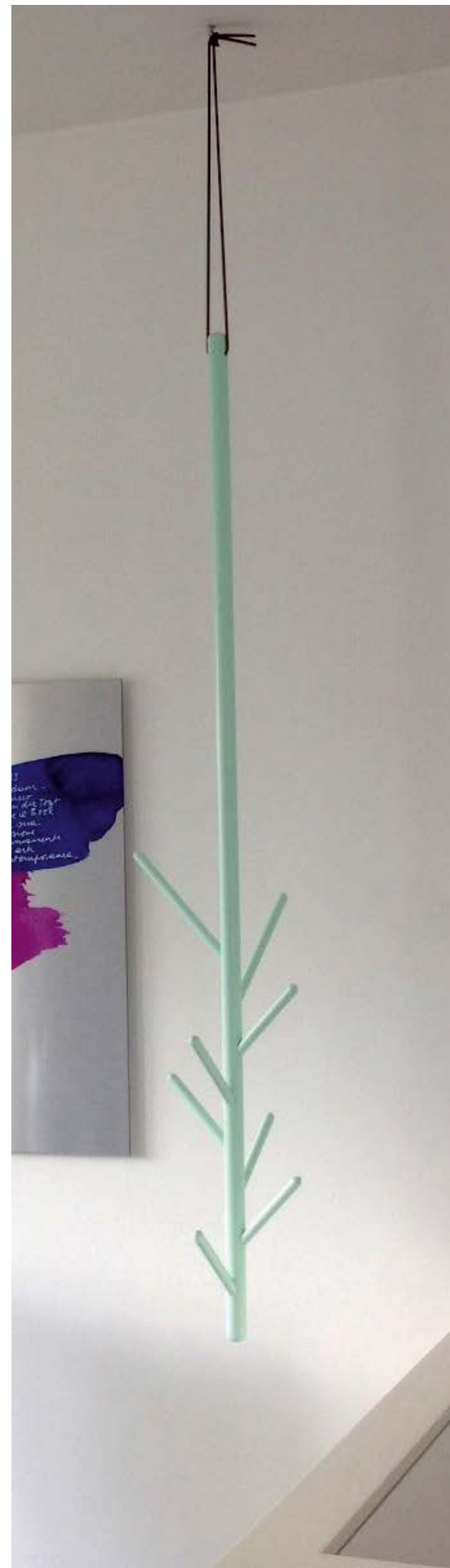

Spillo
a terra

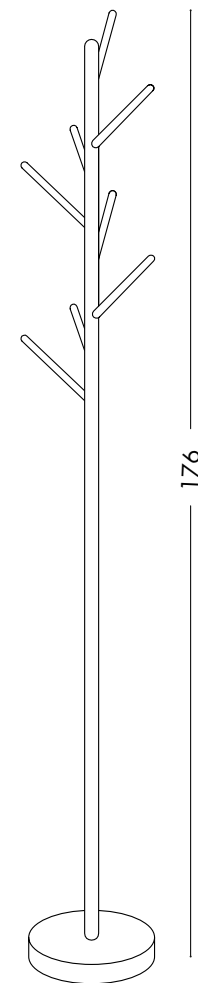

Spillo
sopseso

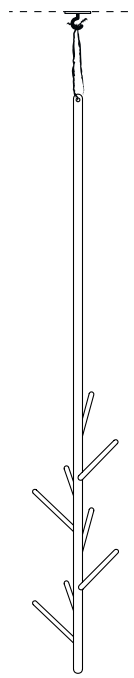
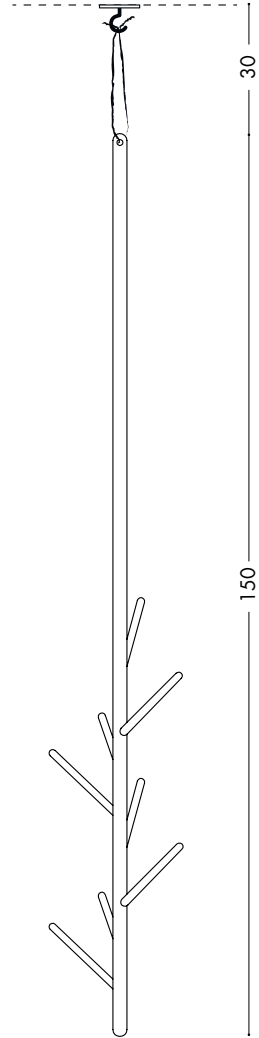

Laccetto cuio e gancio soffitto
Bianco Lipari
Sunny
Baby
Navy

With leather string and ceiling hook
Lipary white
Sunny
Baby
Navy

